

# FX2NC SERIES



extremely compact

*The New  
Programmable  
Controller*

## Contents

|                       |           |
|-----------------------|-----------|
| <b>Overview</b>       | <b>1</b>  |
| Overview              | 2         |
| <b>Features</b>       | <b>3</b>  |
| Features              | 4         |
| Features              | 5         |
| Features              | 6         |
| Features              | 7         |
| Features              | 8         |
| <b>Specifications</b> | <b>9</b>  |
| Specifications        | 10        |
| Specifications        | 11        |
| Specifications        | 12        |
| <b>Dimensions</b>     | <b>13</b> |
| Dimensions            | 14        |

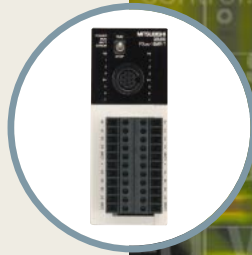
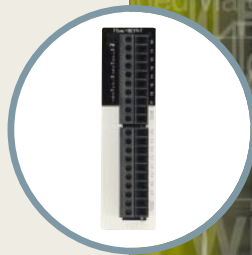

# **PERFORMANCE and VERSATILITY** **in One Ultra Compact Micro** **Programmable Controller**

The FX2NC series is both highly compact and technologically advanced, boasting superb performance and sophisticated features. It increases your creativity by making your imagination come to life in a comfortable operating environment. Truly a new world for micro programmable controllers.

## **Ultra Compact**

Only 35mm wide by 90mm high, yet gives you control over 32 I/O unit.

## **Handles up to 256 I/Os**

Small, but can handle up to 256 I/Os (when expanded).

## **Full Communications Capabilities**

You can build a versatile network with simple PC links, computer links, and serial links.

## **Wiring Is Very Easy**

European Terminal Connectors make I/O connections quick and simple.

## **High Performance and Sophisticated Features**

With an FX2NC series-compatible CPU even special applications are easily handled. You can output two PLSY instructions at once.

## **Common Peripherals**

Shares peripherals with the whole FX series, so you can monitor and write programs.

## **Memory Board Capability**

You can expand memory and/or add a Real Time Clock by using one of the four available memory board.

## **Battery Included as Standard**

These programmable controllers can store large quantities of data for long periods of time. This also makes it easy to bring equipment back on line after a long power outage.

## **Good for New Applications**

The capabilities of the FX2NC enable it to perform superlatively in many applications.



# Features

## An Extra Dimension of Versatility for the Powerful FX2NC Series

### ■ DC Input/Relay Output Model with a Greater Range of Applications

New relay output model can be used in multiple connection configurations with the popular connector type, providing more flexible system configuration with maximum compactness.

Unit: mm (inch)



### FX<sub>2</sub>NC-16MR-T-DS

Base 16-pin unit

**DC input: 8 inputs**  
(DC 24V)

**Relay output: 8 outputs**  
2A/1-pin (4A/per common)

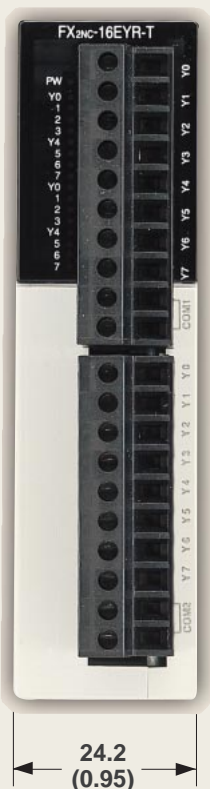
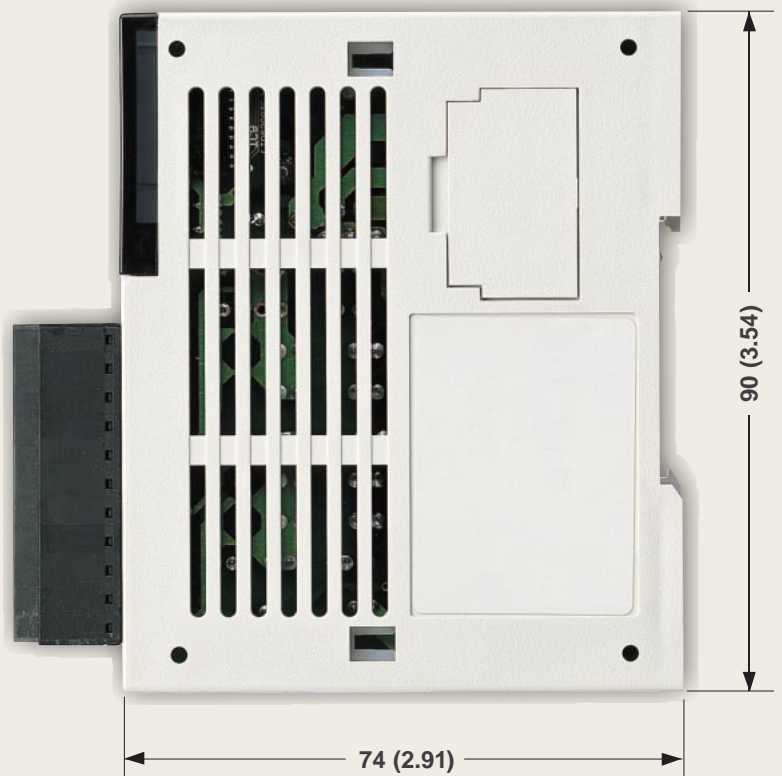

### FX<sub>2</sub>NC-16EYR-T-DS

16-pin output extension block

**Relay output: 16 outputs**  
2A/1 pin (4A/per common)

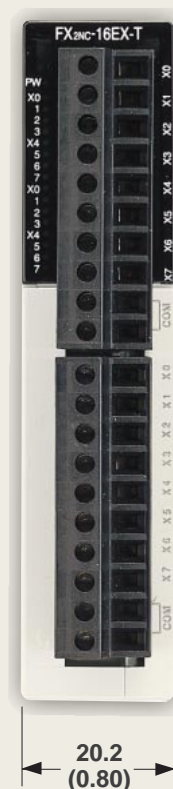

### FX<sub>2</sub>NC-16EX-T-DS

16-pin input extension block

**DC input: 16 inputs**  
(DC 24V)

## ■ Easy Wiring with Front Panel Fasteners and Removable Terminal Blocks

Stranded wire or single core wire from 0.3mm<sup>2</sup> to 0.5mm<sup>2</sup> (AWG22 to 20) can be connected to European style terminals without crimp type connectors. (Can accommodate up to two 0.3mm<sup>2</sup> wires.) Cylindrical terminals fitted with the prescribed insulation sleeve (refer to Phoenix Contact products on Page 7) can also be used.

Stranded wires or single core wire connection



Insulated cylindrical terminal connections

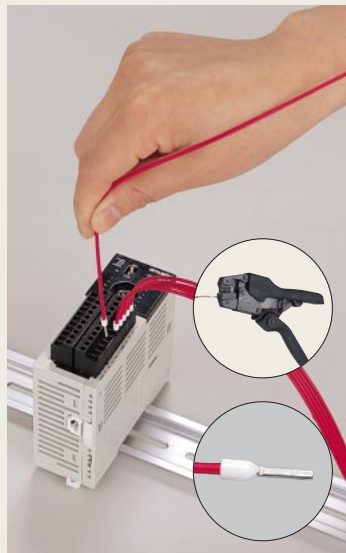

■ Easy wiring access from the front panel



■ Fitting and removal by touch

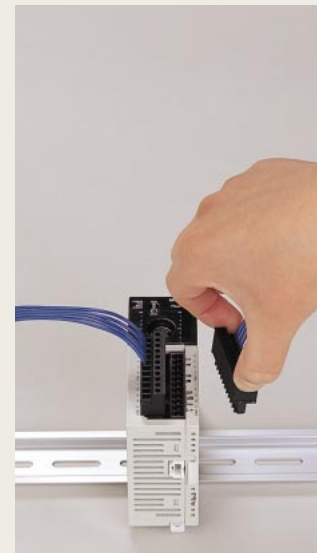

### Screwdriver for European style terminal block

Please ensure that the screwdriver meets the following specifications.

Market product: 0.4mm blade thickness/2.5mm blade width (the tip is a straight driver)

Phoenix contact product: SZS 0.4x2.5 model (Refer to Page 7 for inquiries).

## ■ Many of Combinations Give Wide-Ranging Options and Uses

Can accommodate both terminal block types and connector types.

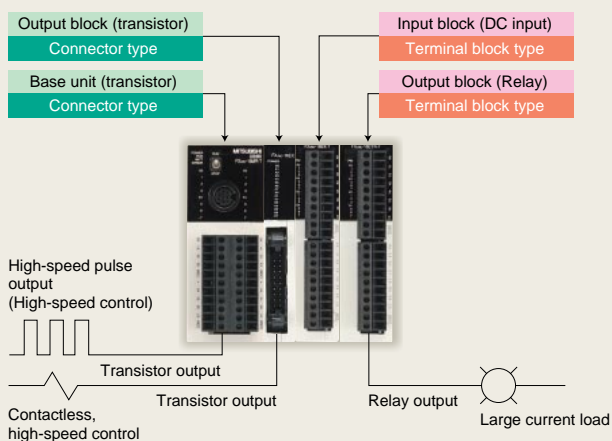

"High-speed control with transistor output" and "Large current load generated by relay output" in a combination which is still compact in size.

Linking connector type I/O to a terminal block allows AC 100V input and triac output compatibility.

Compatible with a Wide Variety of FX0N and FX2N Devices.

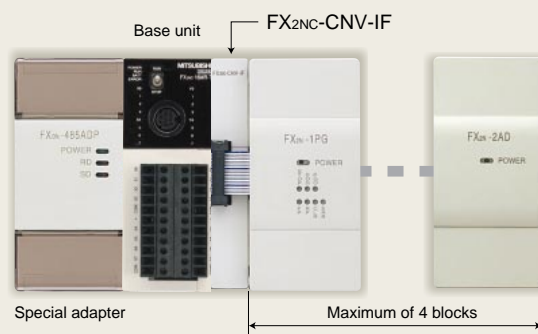

One FX0N special adapter can be connected to the left-hand side of the base unit. A maximum of 4 additional FX0N and FX2N I/O extension blocks and special devices can be connected to the right hand side through a FX2NC-CNV-IF interface.

**Special add ons:** Analogue I/O, thermocouple, PT-100  
Positioning, pulse output, high-speed counter, cam switch.

**Communications/Link:** RS-232C, RS-485, ID system  
Parallel link, simple PC to PC link, computer link.  
I/O link, CC-Link

# Features

Unit: mm (inch)

## FX<sub>2</sub>NC-16MT-DSS / FX<sub>2</sub>NC-32MT-DSS

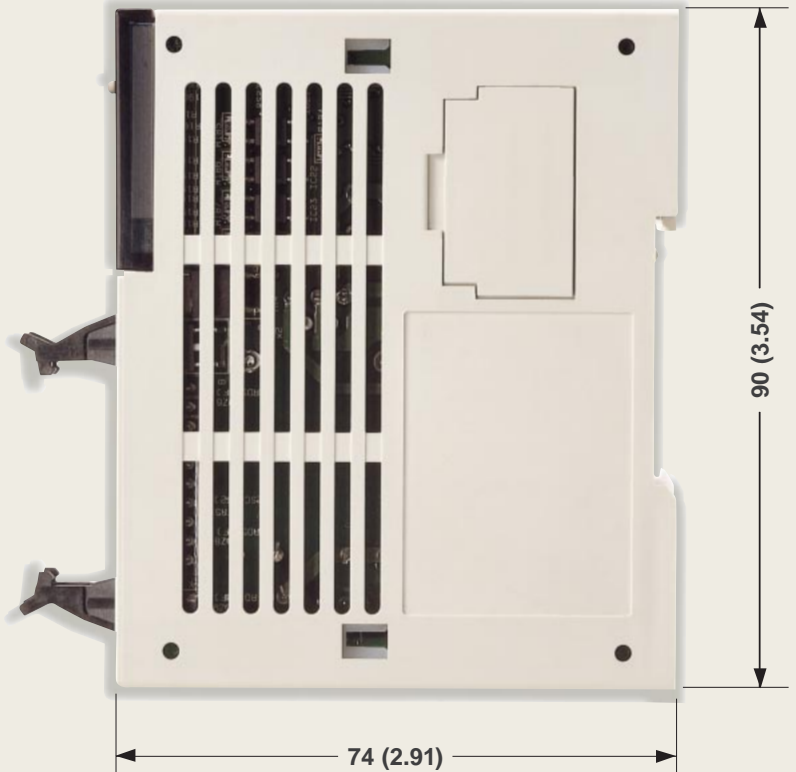

## FX<sub>2</sub>NC-64MT-DSS

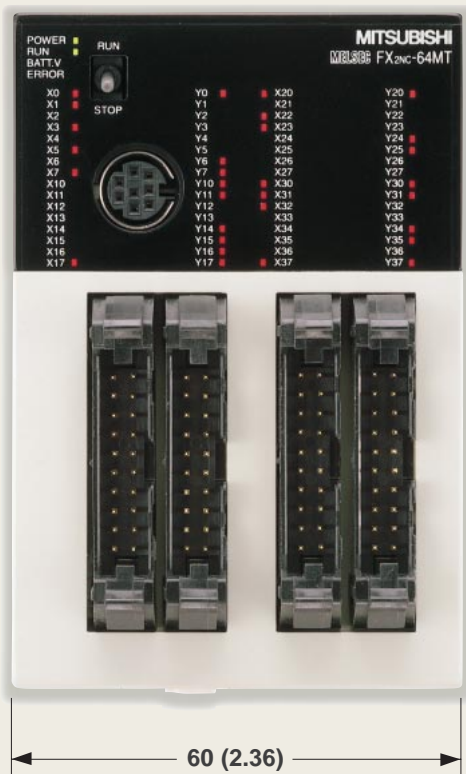

## FX<sub>2</sub>NC-96MT-DSS

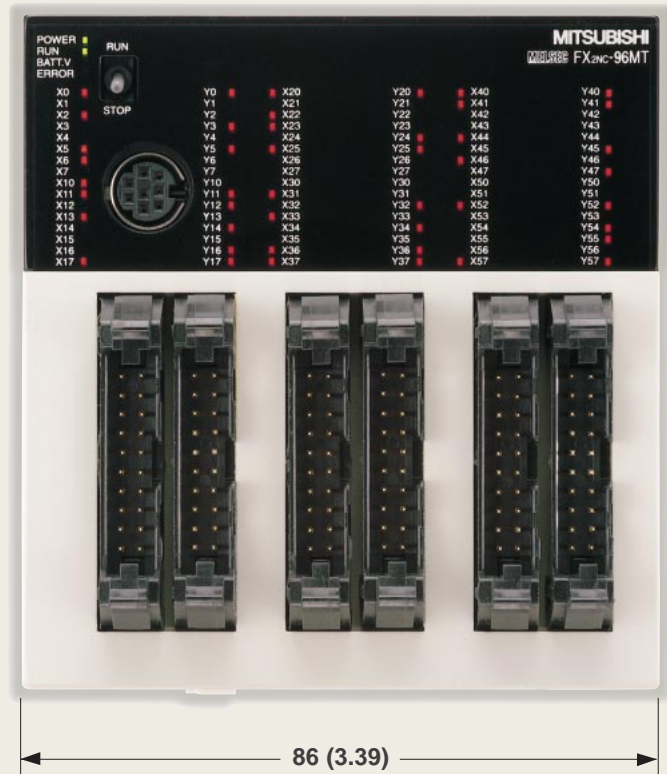

## Super Compact Body / Super Easy Connectors Facilitate Wiring

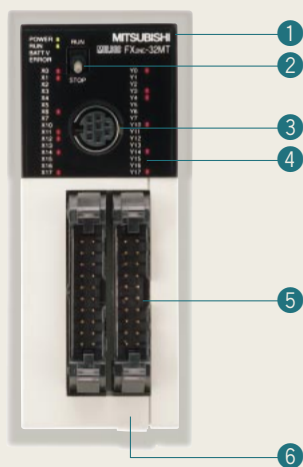

### 1. Built-in CPU and I/Os

The compact body has a built-in CPU and I/Os.

### 2. RUN/STOP Switch

The RUN/STOP switches run or stop the machine.

### 3. Programming Connector

You can share peripherals with FX series CPUs. It uses the same cable as the FX0, FX0s, FX0N, and FX2N.

### 4. I/O Display LED

Shows whether the I/O is On or Off.

### 5. Memory Board

You can use an optional memory board.

### 6. Power Supply Connector

Uses a 24V DC power supply.

## Handles 256 I/Os / Connect Special Adapters and Blocks

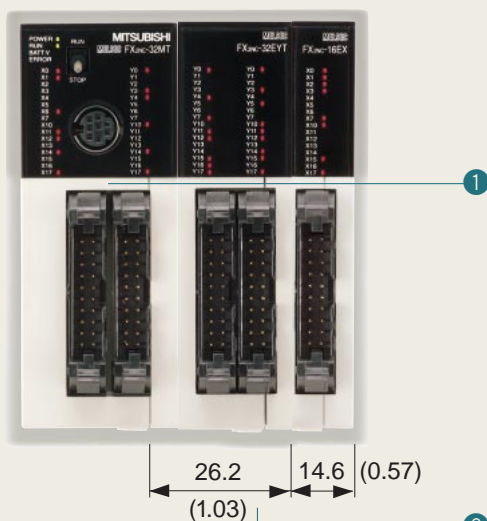

Unit: mm (inch)

### 1. Base Unit

16-, 32-, 64-, and 96-point units will go on sale sequentially. (All are 24V DC power supply/transistor output types.)

### 2. Extension Blocks

Connect 16- or 32-point extension blocks to provide coverage of up to 256 points. The FX0N or FX2N extension blocks require FX2NC-CNV-IF interfaces.

### 1. Special Adapters

You can use the special adapters for the FX0N.

- FX0N-232ADP (for RS-232C)
- FX0N-485ADP (for RS-485)

### 2. Interface for Extension Block Connections

This interface is for the extension blocks for the FX0N and FX2N and for the special extension block.

- Extension Block

The FX2NC, which can be connected to all machines for the FX0N and FX2N, is constructed solely of extension blocks. It does not take extension units.

### 3. Special Blocks

- Analog
  - FX2N-4AD: Analog input (4 channels)
  - FX2N-4DA: Analog output (4 channels)
  - FX2N-4AD-PT: For PT-100 (4 channels)
  - FX2N-4AD-TC: For thermocouples (4 channels)
  - FX0N-3A: Analog I/Os (3 channels)
- High-Speed Counter FX2N-1HC: Two-phase, 50kHz
- Positioning FX2N-1PG-E: One axis, 100Kbps
- MELSECNET/MINI interface FX0N-16NT: For twisted pair cable
- Programmable Cam Switch FX2N-1RM-E: Detects angle of rotation
- RS-232C Communications Interface FX2N-232IF: Asynchronous full duplex

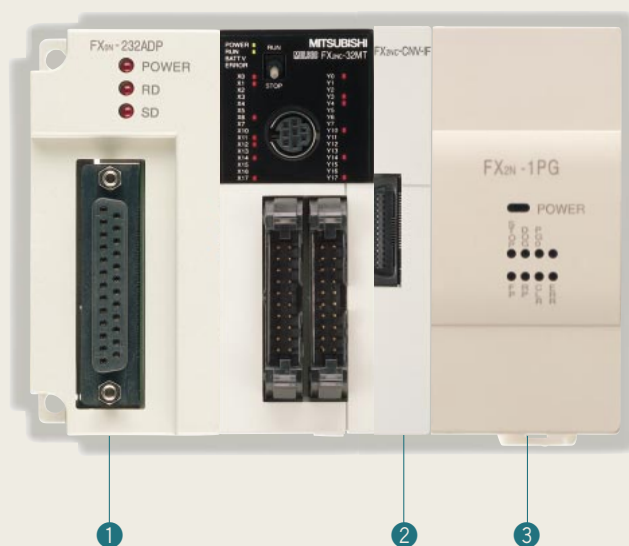

# Features

## Comprehensive Range of Optional Memory Boards (With real-time clock function)



Optional boards with clock function specially designed for the FX2NC series.

Board with clock function added to the sequencer only and board with integrated EEPROM memory and clock function are available.

**FX2NC-RTC:** Additional clock function only (Uses on-board RAM memory)

**FX2NC-EEPROM-4C:** 4K step EEPROM memory + clock function

**FX2NC-EEPROM16C:** 16K step EEPROM memory + clock function

**FX2NC-EEPROM-16:** 16K step EEPROM memory (no clock function)

## DC Power Unit (DC24V 2A)



DC24V Power Supply

A DC power unit with the same system design as the sequencer. It can be used as a power source for DC24V model sequencers, special blocks or sensors

Soon to be released: **FX2N-20PSU**





Input voltage: AC85-264V 50/60Hz

Output voltage: DC24V  $\pm 10\%$

Output current: 2A (FX2N-20PSU)

Safety functions: Output current overload protector

## Wiring Components for Terminal Block, I/O Connector/ I/O Terminal Block

|  |  |  |   |                                    |   |
|--|--|--|---|------------------------------------|---|
| <b>Terminal Block</b><br>                 | <b>Model</b>                                       | <b>Input pins</b>  | <b>Output pins</b>  | <b>Remarks</b>                     |   |
|  | FX-16E-TB/UL                                       | 16 input or 16 output  |   |                                    | Connected directly to sequencer I/O terminals |
|  | FX-32E-TB/UL                                       | 32 input or 32 output<br>Can be set up as 16 input and 16 output |   |                                    |   |
|  | FX-16EX-A1-TB/UL                                   | 16   | –   | AC100V signal input type           |   |
|  | FX-16EYR-ES-TB/UL                                  | –  | 16  | Relay output type                  |   |
|  | FX-16EYS-ES-TB/UL                                  | –  | 16  | Triac output type                  |   |
| FX-16EYT-ESS-TB/UL   | –  | 16   | Transistor output type  |                                    |   |
| <b>I/O Cable</b><br>                      | <b>Model</b>                                       | <b>Meters</b>  | <b>Usage</b>  |                                    |   |
|  | FX-16E-500CAB-S                                    | 5m   | General purpose I/O cable (20-pin connector on one end of the unsheathed cable only).                                 |                                    |   |
|  | FX-16E-150CAB                                      | 1.5m   | For use with FX-16/32E□□-TB terminal blocks<br>Flat cable (with sheathing) fitted with 20-pin connectors at both end. |                                    |   |
|  | FX-16E-300CAB                                      | 3m   |   |                                    |   |
|  | FX-16E-500CAB                                      | 5m   |   |                                    |   |
|  | FX-16E-150CAB-R                                    | 1.5m   | For use with FX-16/32E□□-TB/UL terminal blocks<br>Round, multi-core cable with 20-pin connectors at both ends.        |                                    |   |
|  | FX-16E-300CAB-R                                    | 3m   |   |                                    |   |
|  | FX-16E-500CAB-R                                    | 5m   |   |                                    |   |
|  | FX-A32E-150CAB                                     | 1.5m   | Connector cable linking A-series A6TBXY36 connector/terminal block conversion unit and connector type I/O sequencer.  |                                    |   |
| FX-A32E-300CAB   | 3m   |  |   |                                    |   |
| FX-A32E-500CAB   | 5m   |  |   |                                    |   |
| <b>I/O Connector</b><br>                  | <b>Model &amp; Configuration</b>                   |  | <b>Applicable Electrical Cables</b>   |                                    |   |
|  | <b>Mitsubishi Electric Model</b>                   | <b>Part (Dai-Ichi Denshi product)</b>                            | <b>Cable Size</b>   |                                    |   |
|  | FX2c-I/O-CON<br>For flat cable: 10                 | Crimp connector: FRC2-A020-3T0S                                  | AWG28 (0.1mm <sup>2</sup> )1.27 pitch 20 core   |                                    |   |
|  | FX2c-I/O-CON-S<br>For unsheathed wires: 5-set      | Housing: HU-200S2-001<br>Crimp connector: HU-411S                | AWG22 (0.3mm <sup>2</sup> )   |                                    |   |
| FX2c-I/O-CON-SA<br>For unsheathed wires: 5-set   | Housing: HU-200S2-001<br>Crimp connector: HU-411SA | AWG20 (0.5mm <sup>2</sup> )                                      |   |                                    |   |
| <b>Insulated cylindrical terminal</b><br> | <b>Model (Phoenix Contact recommended)</b>         |  | <b>Applicable Electrical Cables</b>   |                                    |   |
|  | AI 0.5-8 WH (Inside diameter of insulation: 2.6mm) |  | <b>Cable Size</b>   |                                    |   |
|  |  |  |   | AWG22–20 (0.3–0.5mm <sup>2</sup> ) |   |

## CPU Boasts High Performance and Sophisticated Features / Shared Peripherals Full Communications Capabilities



### 1. Programming Capacity

8K step of built-in RAM. (Expandable to 16K steps using the optional memory board.)

### 2. Fast Operations

0.08μs for a basic instruction.

### 3. Lots of Instructions

27 basic instructions, two stepladder instructions, and 128 application instructions for a total of 298 instructions.

- Pulse output detection for positioning. Can use two PLSY or PLSR instructions simultaneously (20kHz/point or 10kHz/2 points).
- Pulse width modulation
- PID control instruction
- Square roots
- Matrix inputs
- Time-sharing I/Os

### 4. High-Speed Counter

Can get high-speed inputs.

- 1-Phase 60Hz: Two points, 10kHz: 4 points
  - 2-Phase 30Hz: One point, 5kHz: 1 point
- Also has instructions for the high-speed counter.

### 5. Basic Functions You Can Use

- Pulse catch/input interrupts
- Constant scans
- Register keywords
- Change programming while running

**FX2N equivalent CPU.**



### 1. For Writing Programs

Uses the same peripherals as the FX series. Also uses the same cable as the FX0, FX0S, FX0N, and FX2N.

- Personal computer

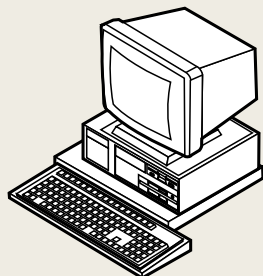

### 2. Human Machine Interface (HMI)

Can use anything from the compact FX-10DU through the color display F940GOT.

Connections use the same cable as the FX0, FX0S, FX0N, and FX2N.



F940GOT-SWD-E

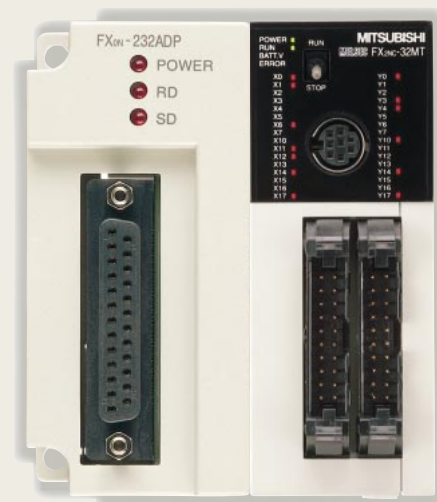

### 1. RS-232C Communications

Can communicate with any equipment that has an RS-232C interface.

- Personal computer
- Printer
- Bar code reader etc.

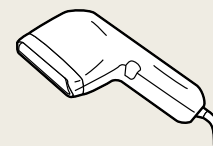
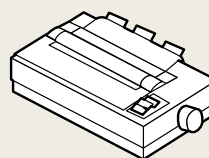
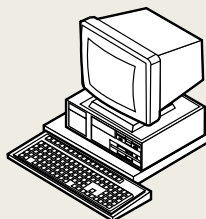

### 2. RS-485 Communications

- Parallel link: Transfers data between two base units.
- Computer link: Connects up to 16 base units through a computer host. (You can connect both FX0N and FX2N machines in a single system.)
- Simple PC link: Transfers data among up to eight base units. (You can connect both FX0N, FX2N and A1FX machines in a single system.)

\*RS-232C adapter for the FX0N-232ADP shown.

# Specifications

## General Specifications

|                       |   |   |
|-----------------------|---|---|
| Ambient temperature   | Use: 0 to 55°C, Storage: -20 to +70°C   |   |
| Ambient humidity      | Use: 35 to 85% RH (no condensation)   |   |
| Vibration resistance  | Shall conform to JIS C0911, 10 to 55Hz, 0.5mm (maximum 0.5G, DIN rail)<br>in all three axis directions for 2 hoursImpact resistance |   |
| Impact resistance     | Shall conform to JIS C0912, 10G three times each in all three axis directions.  |   |
| Noise resistance      | Noise voltage 1000VP-P on a noise simulator with a noise width of 1μ sec and a frequency of 30 to 100Hz                             |   |
| Dielectric strength   | AC 1500V for one minute   | Between all terminals and ground terminal |
| Insulation resistance | 5MΩ or more with DC 500V megger   |   |
| Ground                | Class 3 grounding   |   |
| Ambient environment   | No corrosive gases, no dusty locations.   |   |

## Power Specifications

| Model       |                 | Item                           | Supply voltage | Permissible sudden stop time                         | Supply fuse | Power consumption |
|-------------|-----------------|--------------------------------|----------------|--|-------------|-------------------|
| FX2NC based | FX2NC-16MT-DSS  | 24V DC +20% -15%,<br>ripple 5% |                | Operation continues for sudden stops of 5ms or less. | 250V 3A     | 6W                |
|             | FX2NC-32MT-DSS  |                                |                |  |             | 8W                |
|             | FX2NC-64MT-DSS  |                                |                |  |             | 11W               |
|             | FX2NC-96MT-DSS  |                                |                |  |             | 14W               |
|             | FX2NC-16MR-T-DS |                                |                |  | 125V 2.5A   | 6W                |

## Input Specifications

| Item                    | DC input   |               |
|-------------------------|--|---------------|
| Machine                 | X0 to X7   | X10 or higher |
| Input signal voltage    | 24V DC+20% -15%  |               |
| Input signal current    | 7mA / 24V DC   | 5mA / 24V DC  |
| Input ON current        | 4.5mA minimum  | 3.5mA minimum |
| Input OFF current       | 1.5mA maximum  | 1mA maximum   |
| Input response time     | About 10 ms, but X0 to X17 can vary between 0 and 60ms |               |
| Input signal format     | No voltage contact or NPN open collector transistor    |               |
| Circuit insulation      | Photocoupler insulation                                |               |
| Input operation display | LED lights when input is ON circuit configuration      |               |

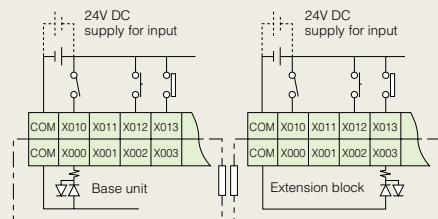

## Output Specifications

| Item                     | Relay output                                       | Transistor output   |
|--------------------------|--|---|
| External power supply    | Max. AC250V DC30V                                  | DC 5V-30V   |
| Maximum load             | Resistance load                                    | 0.3A/point (Y0-Y3),<br>0.1A/point (Y4 up)   |
|                          | Inductive load                                     | 7.2W/24V DC (Y0-Y3),<br>2.4W/24V DC (Y4 up)   |
|                          | Lamp load  | 0.9W/24V DC (Y0-Y3),<br>0.75W/24V DC (Y4 up)  |
| Circuit leakage current  | -  | 0.1mA maximum   |
| Response time            | Approx. 10ms                                       | When ON, 0.2ms maximum;<br>when OFF, 0.2ms maximum.<br>For Y0 and Y1, when ON,<br>0.01ms maximum;<br>when OFF, 0.03 ms maximum. |
| Circuit insulation       | LED is lit when current passes through relay coil. | Photocoupler insulation   |
| Output operation display | Mechanical insulation                              | LED lights when photocoupler is driven  |

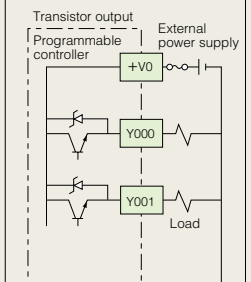
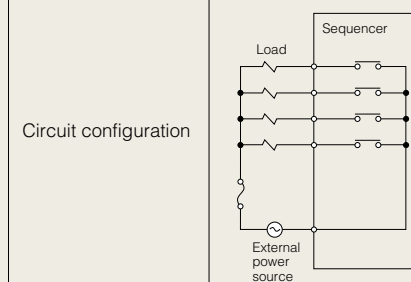

## Performance Specifications

|                                  |                               |  |  |
|----------------------------------|-------------------------------|--|--|
| Operation control method         |                               | Cyclic operation by stored program, performed by dedicated LSI.                              |  |
| I/O refresh method               |                               | Batch processing when END instruction is executed. I/O refresh instructions available.       |  |
| Operation processing time        | Basic instruction             | 0.08μs per instruction   |  |
|                                  | Applied instruction           | 1.52μs – several 100μs per instruction   |  |
| Programming language             |                               | Relay symbolic language + Stepladder. SFC expression possible.                               |  |
| Program capacity and memory type |                               | Built-in 8K step RAM; 16K step max.<br>RAM, EPROM, EEPROM memory cassettes can be installed. |  |
| Number of instructions           | Basic, stepladder             | Basic (sequence): 27; stepladder: 2  |  |
|                                  | Applied                       | 298  |  |
| Input relay                      |                               | 184 points X0–X267   |  |
| Output relay                     |                               | 184 points Y0–Y267   |  |
| Auxiliary relay                  | General use                   | 500 points M0–M499   |  |
|                                  | Latch*                        | 2572 points M500–M3071   |  |
|                                  | Special purpose               | 256 points M8000–M8256   |  |
| State                            | General use                   | 490 points S10–S499  |  |
|                                  | Latch*                        | 400 points S500–S899   |  |
|                                  | Annunciator                   | 100 points S900–S999   |  |
| Timer                            | 100ms                         | 200 points T0–T199   |  |
|                                  | 10ms                          | 46 points T200–T245  |  |
|                                  | 1ms retentive                 | 4 points T246–T249   |  |
|                                  | 100ms retentive               | 6 points T250–T255   |  |
| Counter                          | Up counter                    | General use  | 100 points (16-bit) C0–C99   |
|                                  |                               | Latch*   | 100 points (16-bit) C100–C199  |
|                                  | Up-down counter               | General use  | 20 points (32-bit) C200–C219   |
|                                  |                               | Latch*   | 15 points (32-bit) C220–C234   |
|                                  | High-speed counter            |  | 1-phase: 60kHz – 2 points 10kHz – 4 points<br>2-phase: 30kHz – 1 point 5kHz – 1 point          |
| Data register                    | General-purpose data register | General use  | 200 points (16-bit) D0–D199  |
|                                  |                               | Latch*   | 7800 points (16-bit) D200–D7999  |
|                                  | Special register              |  | 256 points (16-bit) D8000–D8255  |
|                                  | Index                         |  | 16 points (16-bit) V0–V7, Z0–Z7  |
|                                  | File register 16-bit          |  | File registers can be set in 500-register units from general-purpose register D1000 and above. |
| Pointer                          | For JUMP/CALL                 |  | 128 points P0–P127   |
|                                  | Interrupt                     |  | 15 points 0□□□ – I8□□□   |
| Nesting                          |                               | 8 points N0–N7   |  |
| Number ranges                    | Decimal                       | 16 bits: –32,768~+32,767; 32 bits: –2,147,483,648~+2,147,483,647                             |  |
|                                  | Hexadecimal                   | 16 bits: 0-FFFFH; 32 bits: 0-FFFFFFFFH   |  |

Battery backup\*: Parameters for scope of battery backup adjustable. Note: Fixed battery backup for M1024-M3071, D512-D7999.

# Specifications

## List of Instructions - 27 Basic instructions

| Mnemonic | Function                              | Target Element       |
|----------|---------------------------------------|----------------------|
| LD       | Normally-open initial contact         | X, Y, M, S, T, C     |
| LDI      | Normally-closed initial contact       | X, Y, M, S, T, C     |
| OUT      | Output coil                           | X, Y, M, S, T, C     |
| AND      | Normally-open contact in series       | X, Y, M, S, T, C     |
| ANI      | Normally-closed contact in series     | X, Y, M, S, T, C     |
| OR       | Normally-open contact in parallel     | X, Y, M, S, T, C     |
| ORI      | Normally-closed contact in parallel   | X, Y, M, S, T, C     |
| ANB      | Serial connection of circuit blocks   | None                 |
| ORB      | Parallel connection of circuit blocks | None                 |
| NOP      | No-operation                          | None                 |
| SET      | Latched output drive ON               | Y, M, S              |
| RST      | Latched output drive OFF              | Y, M, S, T, C, D     |
| PLS      | Pulse output (OFF/ON trigger)         | Y, M                 |
| PLF      | Pulse output (ON/OFF trigger)         | Y, M                 |
| MC       | Beginning of master control           | Y, M                 |
| MCR      | End of master control                 | None                 |
| MPS      | Result store (Push)                   | None                 |
| MRD      | Result read (Read)                    | None                 |
| MPP      | Result clear (Pop)                    | None                 |
| END      | End of program                        | None                 |
| LDP      | Initial ON pulse operation            | X, Y, M, S, T, C NEW |
| LDF      | Initial OFF pulse operation           | X, Y, M, S, T, C NEW |
| ANDP     | Serial connection of ON pulse         | X, Y, M, S, T, C NEW |
| ANDF     | Serial connection of OFF pulse        | X, Y, M, S, T, C NEW |
| ORP      | Parallel connection of ON pulse       | X, Y, M, S, T, C NEW |
| ORF      | Parallel connection of OFF pulse      | X, Y, M, S, T, C NEW |
| INV      | Result invert                         | None NEW             |

## 128 Applied Instructions

| FNC. No. | 1    | 2   | 3   | Details  |
|----------|------|-----|-----|--|
| 0        | CJ   |     | Yes | Conditional Jump - Skip instruction                  |
| 1        | CALL |     | Yes | Sub-Routine Call - Call routine outside main program |
| 2        | SRET |     |     | Sub-Routine Return - Return to main program          |
| 3        | IRET |     |     | Interrupt Return - Return from an interrupt routine  |
| 4        | EI   |     |     | Interrupt Enable - Enable interrupt processing       |
| 5        | DI   |     |     | Interrupt Disable - Disable interrupt processing     |
| 6        | FEND |     |     | First End - End main program                         |
| 7        | WDT  |     | Yes | Watchdog Timer - Refresh error detector              |
| 8        | FOR  |     |     | For - Begin repeat loop                              |
| 9        | NEXT |     |     | Next - End repeat loop                               |
| 10       | CMP  | Yes | Yes | Compare - Compare to obtain <, =, > results          |
| 11       | ZCP  | Yes | Yes | Zone Compare - Compare range of data to one value    |
| 12       | MOV  | Yes | Yes | Move - Copy data                                     |
| 13       | SMOV |     | Yes | Shift Move - Manipulate decimal digit                |
| 14       | CML  | Yes | Yes | Complement - Invert value                            |
| 15       | BMOV |     | Yes | Block Move - Copy a block of data                    |
| 16       | FMOV | Yes | Yes | Fill Move - Copy one data to multiple locations      |
| 17       | XCH  | Yes | Yes | Exchange - Swap data                                 |

| FNC. No. | 1    | 2   | 3   | Details   |
|----------|------|-----|-----|---|
| 18       | BCD  | Yes | Yes | Binary Coded Decimal - Convert binary into BCD                                      |
| 19       | BIN  | Yes | Yes | Binary - Convert BCD into binary  |
| 20       | ADD  | Yes | Yes | Add - Add two values and store result   |
| 21       | SUB  | Yes | Yes | Subtract - Subtract one value from another and store result                         |
| 22       | MUL  | Yes | Yes | Multiply - Multiply two values and store result                                     |
| 23       | DIV  | Yes | Yes | Divide - Divide one value by another and store result                               |
| 24       | INC  | Yes | Yes | Increment - Increment a value by 1  |
| 25       | DEC  | Yes | Yes | Decrement - Decrement a value by 1  |
| 26       | WAND | Yes | Yes | Word AND - Logical AND between data words   |
| 27       | WOR  | Yes | Yes | Word OR - Logical OR between data words   |
| 28       | WXOR | Yes | Yes | Word Exclusive OR - Logical XOR operation   |
| 29       | NEG  | Yes | Yes | Negation - Invert sign of complement+1  |
| 30       | ROR  | Yes | Yes | Rotation Right - Rotate bit devices to right  |
| 31       | ROL  | Yes | Yes | Rotation Left - Rotate bit devices to left  |
| 32       | RCR  | Yes | Yes | Rotation Right with Carry - ROR + store carry bit                                   |
| 33       | RCL  | Yes | Yes | Rotation Left with Carry - ROL + store carry bit                                    |
| 34       | SFTR |     | Yes | Shift Right - Shift content of bit device stack to right                            |
| 35       | SFTL |     | Yes | Shift Left - Shift content of bit device stack to left                              |
| 36       | WSFR |     | Yes | Word Shift Right - Shift content of word device stack to right                      |
| 37       | WSFL |     | Yes | Word Shift Left - Shift content of word device stack to left                        |
| 38       | SFWR |     | Yes | Shift Register Write - Write to FIFO stack  |
| 39       | SFRD |     | Yes | Shift Register Read - Read from FIFO stack  |
| 40       | ZRST |     | Yes | Zone Reset - Reset a range of consecutive devices                                   |
| 41       | DECO |     | Yes | Decode - Decode a data value to a single data bit                                   |
| 42       | ENCO |     | Yes | Encode - Find which bit is ON   |
| 43       | SUM  | Yes | Yes | Sum - Count the number of ON bits   |
| 44       | BON  | Yes | Yes | Bit on Check - Check status of a bit device   |
| 45       | MEAN | Yes | Yes | Mean - Calculate mean   |
| 46       | ANS  |     |     | Annunciator Set - Start a timing sequence to set an alarm bit ON                    |
| 47       | ANR  |     | Yes | Annunciator Reset - Reset lowest active alarm bit                                   |
| 48       | SQR  | Yes | Yes | Square Root - Return square root of source data (integer result)                    |
| 49       | FLT  | Yes | Yes | Floating Point - Convert integer to floating point notation                         |
| 50       | REF  |     | Yes | Refresh - Refresh I/Os  |
| 51       | REFF |     | Yes | Refresh and Filter Adjust - Refresh, and adjust input filter                        |
| 52       | MTR  |     |     | Matrix - Multiplex I/Os to Read more inputs than the number of I/Os available       |
| 53       | HSCS | Yes |     | High Speed Counter Set - Compare HSC data to a set value to set a bit ON            |
| 54       | HSCR | Yes |     | High Speed Counter Reset - Compare HSC data to a set value to reset a bit OFF       |
| 55       | HSZ  | Yes |     | HSC Zone Compare - Compare HSC data to a selected range to set a bit ON             |
| 56       | SPD  |     |     | Speed Detect - Detect speed by measuring pulse train                                |
| 57       | PLSY | Yes |     | Pulse Y - Produce a pulse train output consisting of a set number of pulses         |
| 58       | PWM  |     |     | Pulse Width Modulation - Produce a pulse train with variable pulse characteristics  |
| 59       | PLSR | Yes |     | Pulse R - Produce a pulse train output with acceleration / deceleration control NEW |
| 60       | IST  |     |     | Initial State - Additional control for stepladder program flow                      |

| FNC. No. | 1    | 2   | 3   | Details  |     |
|----------|------|-----|-----|--|-----|
| 61       | SER  | Yes | Yes | Search - Search for data   |     |
| 62       | ABSD | Yes |     | Absolute Drum Sequence - CAM switch control (absolute setting)                 |     |
| 63       | INCD |     |     | Incremental Drum Sequence - CAM switch control (relative setting)              |     |
| 64       | TTMR |     |     | Teaching Timer - Measure duration of signal, use data to set timer             |     |
| 65       | STMR |     |     | Special Timer - Provide special timer functions                                |     |
| 66       | ALT  |     | Yes | Alternate - Alternate state of bit device on receipt of input                  |     |
| 67       | RAMP |     |     | Ramp - Calculate linear rate of change between data values                     |     |
| 68       | ROTC |     |     | Rotary Table Control - Provide positioning control for rotary table            |     |
| 69       | SORT |     |     | Sort - Sort tabulated data   |     |
| 70       | TKY  | Yes |     | Ten Key - Read selected inputs as though coming from a ten-key keypad          |     |
| 71       | HKY  | Yes |     | Hexadecimal Key - Read selected inputs as though coming from a HEX keypad      |     |
| 72       | DSW  |     |     | Digital Switch - Multiplex read of digital switches                            |     |
| 73       | SEGD |     | Yes | Seven Segment Decoder - Decode stored data to drive 7-segment display directly |     |
| 74       | SEGL |     |     | Seven Segment With Latch - Multiplexed 7-segment display output                |     |
| 75       | ARWS |     |     | Arrow Switch - Create user-defined numeric data entry panel                    |     |
| 76       | ASC  |     |     | ASCII Code - Convert 8-character string to ASCII                               |     |
| 77       | PR   |     |     | Print - Output ASCII data to displays, etc.                                    |     |
| 78       | FROM | Yes | Yes | From - Read from special function block  |     |
| 79       | TO   | Yes | Yes | To - Write to special function block   |     |
| 80       | RS   |     |     | RS Communications - Serial communication control                               |     |
| 81       | PRUN | Yes | Yes | Parallel Running - Octal data bit transfer                                     |     |
| 82       | ASCI |     | Yes | ASCII Conversion - Convert from HEX to ASCII                                   |     |
| 83       | HEX  |     | Yes | Hex Conversion - Convert from ASCII to HEX                                     |     |
| 84       | CCD  |     | Yes | Check Code - Perform and end bit sum check                                     |     |
| 85       | VRRD |     | Yes | Variable Read - Read analog values from FX2N-8AV-BD potentiometers             |     |
| 86       | VRSC |     | Yes | Variable Scale - Read position values from FX2N-8AV-BD potentiometers          |     |
| 87       |      |     |     |  |     |
| 88       | PID  |     |     | PID Loop - Proportional, Integral, Derivative control loop                     |     |
| 89       |      |     |     |  |     |
| 118      | EBCD | Yes | Yes | Extended BCD - Convert floating point value to decimal value                   | NEW |
| 119      | EBIN | Yes | Yes | Extended Binary - Convert decimal value to floating point value                | NEW |
| 120      | EADD | Yes | Yes | EADD - Add two floating point values   | NEW |
| 121      | ESUB | Yes | Yes | ESUB - Subtract one floating point value from another                          | NEW |
| 122      | EMUL | Yes | Yes | EMUL - Multiply two floating point values                                      | NEW |
| 123      | EDIV | Yes | Yes | EDIV - Divide one floating point value by another                              | NEW |
| 127      | ESQR | Yes | Yes | Extended SQR - Return the square root of a floating point value                | NEW |
| 129      | INT  | Yes | Yes | Integer - Convert a floating point value to an integer                         | NEW |
| 130      | SIN  | Yes | Yes | Sine - SIN trigonometrical function  | NEW |
| 131      | COS  | Yes | Yes | Cosine - COS trigonometrical function  | NEW |
| 132      | TAN  | Yes | Yes | Tangent - TAN trigonometrical function   | NEW |

| FNC. No. | 1     | 2   | 3   | Details  |     |
|----------|-------|-----|-----|--|-----|
| 160      | TCMP  |     | Yes | Time Compare - Compare clock data                                | NEW |
| 161      | TZCP  |     | Yes | Time Zone Compare - Compare range of time data to one time value | NEW |
| 162      | TADD  |     | Yes | Time Add - Add two time values                                   | NEW |
| 163      | TSUB  |     | Yes | Time Subtract - Subtract one time value from another             | NEW |
| 166      | TRD   |     |     | Time Read - Read time data                                       | NEW |
| 167      | TWR   |     |     | Time Write - Write time data                                     | NEW |
| 170      | GRY   | Yes | Yes | Gray - Convert to gray code                                      | NEW |
| 171      | GBIN  | Yes | Yes | Gray Binary - Reverse gray code conversion to binary             | NEW |
| 224      | LD=   | Yes |     | Initial Comparison contact - active when (S1) = (S2)             | NEW |
| 225      | LD>   | Yes |     | Initial Comparison contact - active when (S1) > (S2)             | NEW |
| 226      | LD<   | Yes |     | Initial Comparison contact - active when (S1) < (S2)             | NEW |
| 228      | LD<>  | Yes |     | Initial Comparison contact - active when (S1) ≠ (S2)             | NEW |
| 229      | LD<=  | Yes |     | Initial Comparison contact - active when (S1) ≤ (S2)             | NEW |
| 230      | LD>=  | Yes |     | Initial Comparison contact - active when (S1) ≥ (S2)             | NEW |
| 232      | AND=  | Yes |     | Comparison contact in series - active when (S1) = (S2)           | NEW |
| 233      | AND>  | Yes |     | Comparison contact in series - active when (S1) > (S2)           | NEW |
| 234      | AND<  | Yes |     | Comparison contact in series - active when (S1) < (S2)           | NEW |
| 236      | AND<> | Yes |     | Comparison contact in series - active when (S1) ≠ (S2)           | NEW |
| 237      | AND<= | Yes |     | Comparison contact in series - active when (S1) ≤ (S2)           | NEW |
| 238      | AND>= | Yes |     | Comparison contact in series - active when (S1) ≥ (S2)           | NEW |
| 240      | OR=   | Yes |     | Comparison contact in parallel - active when (S1) = (S2)         | NEW |
| 241      | OR>   | Yes |     | Comparison contact in parallel - active when (S1) > (S2)         | NEW |
| 242      | OR<   | Yes |     | Comparison contact in parallel - active when (S1) < (S2)         | NEW |
| 244      | OR<>  | Yes |     | Comparison contact in parallel - active when (S1) ≠ (S2)         | NEW |
| 245      | OR<=  | Yes |     | Comparison contact in parallel - active when (S1) ≤ (S2)         | NEW |
| 246      | OR>=  | Yes |     | Comparison contact in parallel - active when (S1) ≥ (S2)         | NEW |

1= Mnemonic 2= 32-bit Operation 3=Pulse Operation

# Dimensions

## External Dimensions

### Terminal Block Type

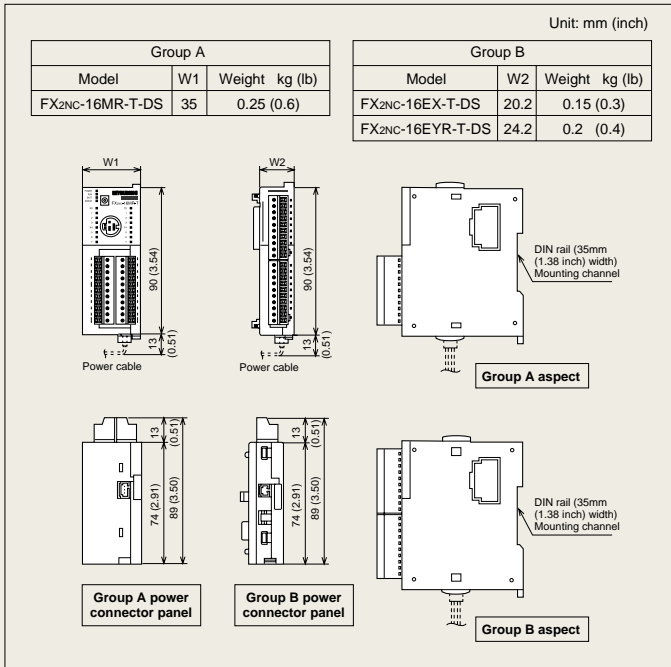

### Connector Type

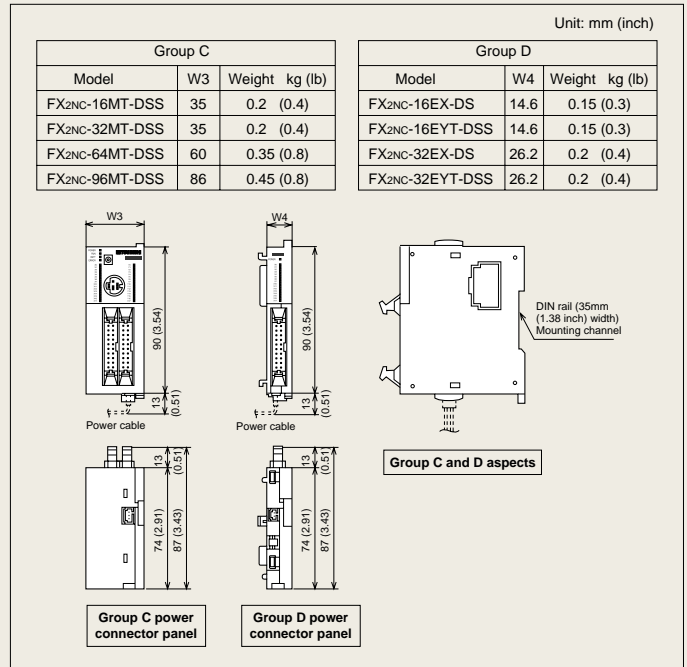

#### Common items and accessories

External color: Munsell 0.08GY/7.64/0.81

Accessories: FX2NC-100MPCB and FX2NC-100BPCB power cables are supplied with the base unit.

I/O serial number labels are supplied with extension blocks.

The FX2NC-10BPCB1 power cable is supplied with input extension blocks.

Note: Connector type products do not include connectors for second parties.

Please select an I/O cable or connector from page 7 or obtain a compatible connector from another source.

## Connector Pin Layout

### Terminal Block Type

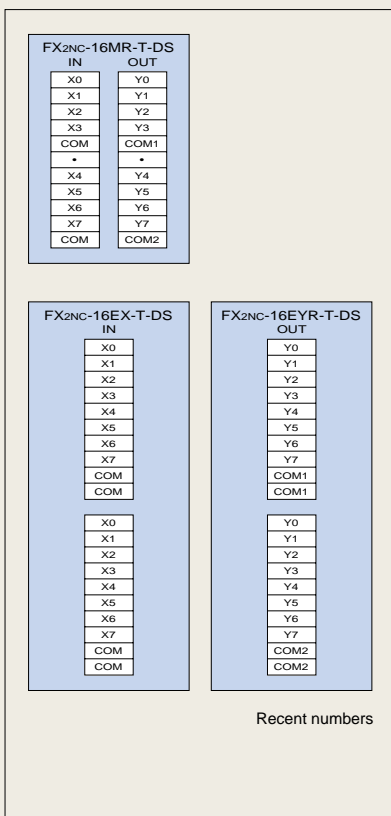

### Connector Type

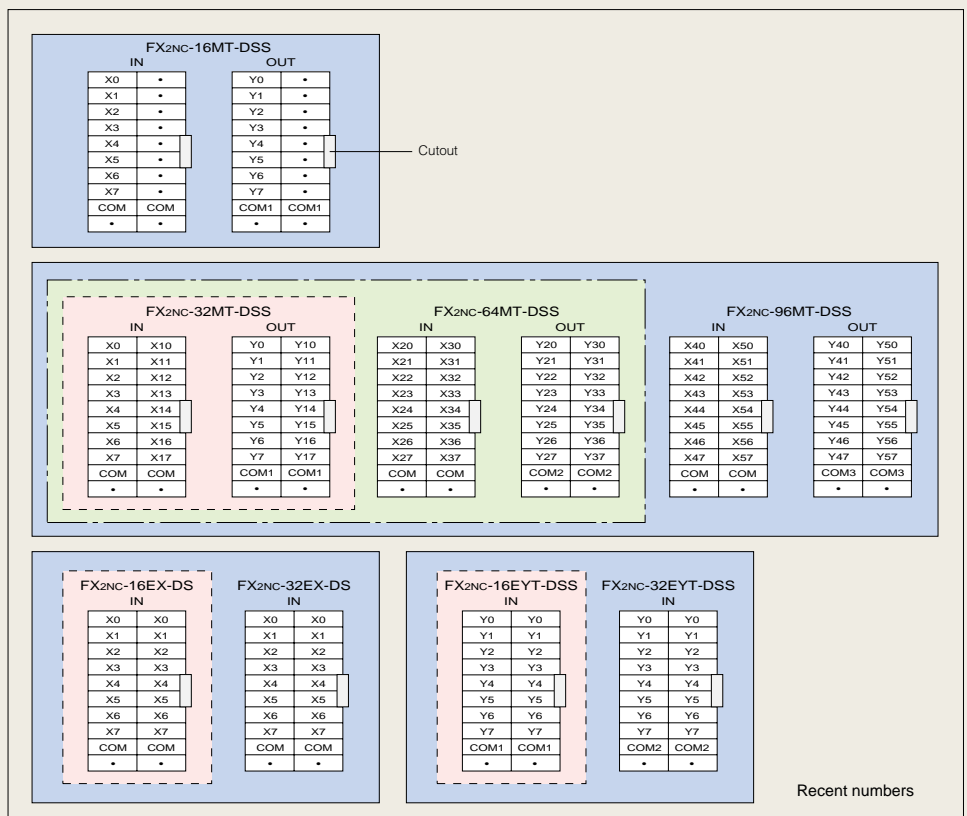

## FX2NC Series Specifications

| Product                          |  | Model  | Specifications  |        |                  |        |                                     |
|----------------------------------|--|--|---|--------|------------------|--------|-------------------------------------|
|                                  |  |  | Supply voltage  | Input  |                  | Output |                                     |
| Base units                       | FX2NC series                               | FX2NC-16MR-T-DS  | 24V DC +20% -15%,<br>ripple 5%  | 8 pts  | 24V DC 7mA / 5mA | 8 pts  | Relay 2A/pt                         |
|                                  |  | FX2NC-16MT-DSS   |   | 8 pts  |                  | 8 pts  | Transistor<br>0.1A/pt (1.6A/16 pts) |
|                                  |  | FX2NC-32MT-DSS   |   | 16 pts |                  | 16 pts |                                     |
|                                  |  | FX2NC-64MT-DSS   |   | 32 pts |                  | 32 pts |                                     |
|                                  |  | FX2NC-96MT-DSS   |   | 48 pts |                  | 48 pts |                                     |
| Extension units/extension blocks | Extension blocks                           | FX2NC-16EX-T-DS  | The control power supply<br>is supplied from<br>the base unit.<br>Only the input block is<br>supplied externally. | 16 pts | 24V DC 5mA       | -      | -                                   |
|                                  |  | FX2NC-16EYR-T-DS   |   | -      | -                | 16 pts | Relay 2A/pt                         |
|                                  |  | FX2NC-16EX-DS  |   | 16 pts | 24V DC 5mA       | -      | -                                   |
|                                  |  | FX2NC-16EYT-DSS  |   | -      | -                | 16 pts | Transistor 0.1A/pt                  |
|                                  |  | FX2NC-32EX-DS  |   | 32 pts | 24V DC 5mA       | -      | -                                   |
|                                  |  | FX2NC-32EYT-DSS  |   | -      | -                | 32 pts | Transistor 0.1A/pt                  |
|                                  |  | FX0N-8ER-ES/UL   |   | 4 pts  | 24V DC 5mA       | 4 pts  | Relay 2A/pt                         |
|                                  |  | FX0N-8EX-ES/UL   |   | 8 pts  |                  | -      | -                                   |
|                                  |  | FX2N-16EX-ES/UL  |   | 16 pts |                  | -      | -                                   |
|                                  |  | FX0N-8EYR-ES/UL  |   | -      | -                | 8 pts  | Relay 2A/pt                         |
|                                  |  | FX0N-8EYT-ESS/UL   |   | -      | -                | 8 pts  | Transistor 0.5A/pt                  |
|                                  |  | FX2N-16EYR-ES/UL   |   | -      | -                | 16 pts | Relay 2A/pt                         |
|                                  |  | FX2N-16EYT-ESS/UL  |   | -      | -                | 16 pts | Transistor 0.5A/pt                  |
| Special extension equipment      | Analog I/O blocks                          | FX0N-3A  | Analog I/O block, 2 input channels, 8 bits, 1 output channel  |        |                  |        |                                     |
|                                  |  | FX0N-16NT  | N-NET/MINI interface block (twisted wire)   |        |                  |        |                                     |
|                                  |  | FX2N-4DA   | 4-channel analog output block   |        |                  |        |                                     |
|                                  |  | FX2N-4AD   | 4-channel analog input block  |        |                  |        |                                     |
|                                  |  | FX2N-2DA   | 2-channel analog output block   |        |                  |        |                                     |
|                                  |  | FX2N-2AD   | 2-channel analog input block  |        |                  |        |                                     |
|                                  |  | FX2N-4AD-PT  | Analog input block for 4-channel temperature sensor   |        |                  |        |                                     |
|                                  | FX2N-4AD-TC                                | Analog input block for 4-channel thermocouple sensor                                     |   |        |                  |        |                                     |
|                                  | High-speed counter                         | FX2N-1HC   | 2-phase 50kHz high-speed counter block  |        |                  |        |                                     |
|                                  | Positioning block                          | FX2N-1PG-E   | Positioning pulse output block, 100K pps  |        |                  |        |                                     |
|                                  | Programmable cam switch                    | FX2N-1RM-E-SET   | Angle of rotation detection unit  |        |                  |        |                                     |
|                                  | Computer link                              | FX-485PC-IF  | Interface for computer link   |        |                  |        |                                     |
|                                  | External equipment communication interface | FX2N-232IF   | Interface for RS-232C communications  |        |                  |        |                                     |
| Extension interface unit         | FX2NC-CNV-IF                               | Interface for connecting extension blocks for FX0N and FX2N and special extension blocks |   |        |                  |        |                                     |
| Interface units                  | FX-232AW                                   | For RS-422/232C conversion (insulated)   |   |        |                  |        |                                     |
|                                  | FX-232AWC                                  | For RS-422/232C conversion (insulated)   |   |        |                  |        |                                     |
| Cables                           | Power supply cables                        | FX2NC-100MPCB  | Power supply cable for base unit 1m   |        |                  |        |                                     |
|                                  |  | FX2NC-100BPCB  | Input power supply cable for extension input block 1m   |        |                  |        |                                     |
|                                  |  | FX2NC-10BPCB1  | Input power supply transmission cable for extension input block 0.1m  |        |                  |        |                                     |
|                                  | Peripheral cables                          | FX2-232CAB   | Data transfer cable (interface to personal computer 25 pins) 3m   |        |                  |        |                                     |
|                                  |  | FX2-232CAB-1   | Data transfer cable (interface to personal computer 9 pins) 3m  |        |                  |        |                                     |
|                                  |  | FX2-232CAB-2   | Data transfer cable (interface to personal computer 14 pins) 3m   |        |                  |        |                                     |
|                                  | Cable adapters                             | FX-422AW0  | Connection cable for RS422 equipment (for insulation) 1.5m  |        |                  |        |                                     |
|                                  |  | FX-20P-CADP  | For FX-20P-CAB, 0.3m  |        |                  |        |                                     |
| Program cable                    | FX-20P-CADP                                | For indirectly connecting FX2NC-FX-10P to 20P, 1.5m                                      |   |        |                  |        |                                     |
| Battery                          | FX2NC-32BL                                 | For memory backup  |   |        |                  |        |                                     |
| Memory board                     | FX2NC-EEPROM-16                            | 16K steps of EEPROM memory   |   |        |                  |        |                                     |



### **Safety Warning**

To ensure proper use of the products listed in this catalog,  
please be sure to read the instruction manual prior to use.

 **MITSUBISHI ELECTRIC CORPORATION**  
HEAD OFFICE: MITSUBISHI DENKI BLDG., 2-2-3, MARUNOUCHI, CHIYODA-KU, TOKYO 100-8310, JAPAN